

**SECTION VIEW**

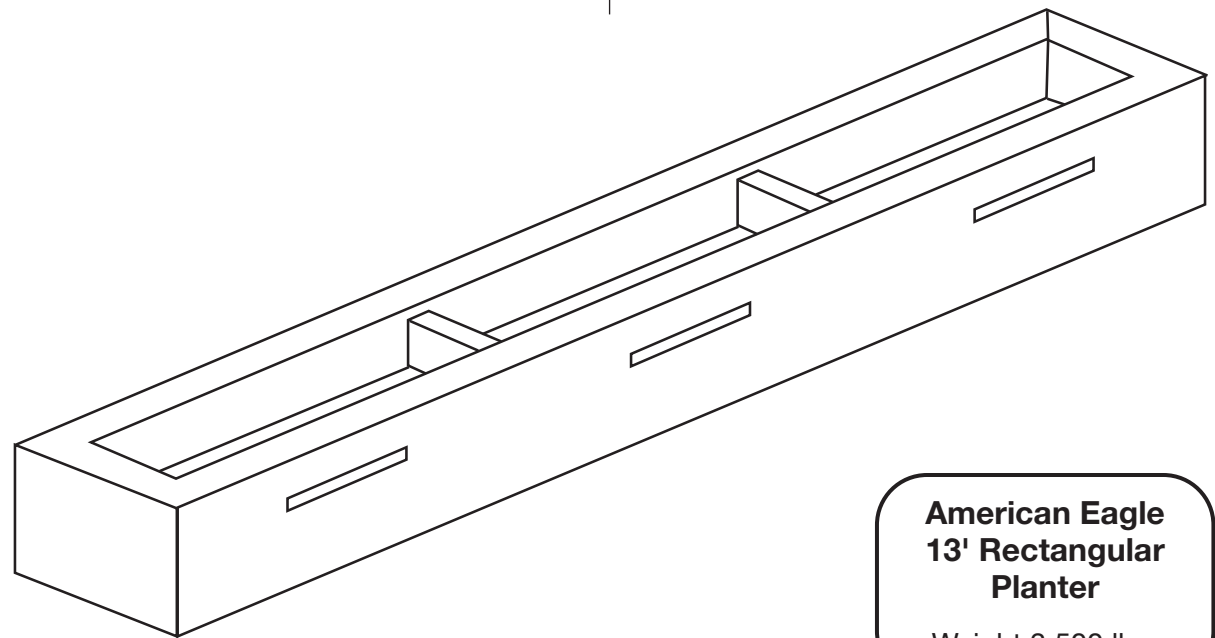

**American Eagle  
13' Rectangular  
Planter**

Weight 3,500 lbs.

- 3/4" diameter drain holes
- Optional LED lighting strips
- Optional spacers
- 2" void space beneath planter for drainage



**AMERICAN EAGLE PRECAST, LLC**

17301 Conant Avenue Detroit, MI 48212-1198

Phone: 313-893-6700 Fax: 313-893-5322

[www.americaneagleprecast.com](http://www.americaneagleprecast.com)