

**SOLID TYPE - 8'**  
General All Purpose Bumper.  
8" Wide, 6" High  
Two  $\frac{3}{8}$ " Reinforcing Rods  
Two  $\frac{1}{6}$ " x 15" Hold Down Pins  
Weight 300 lbs.

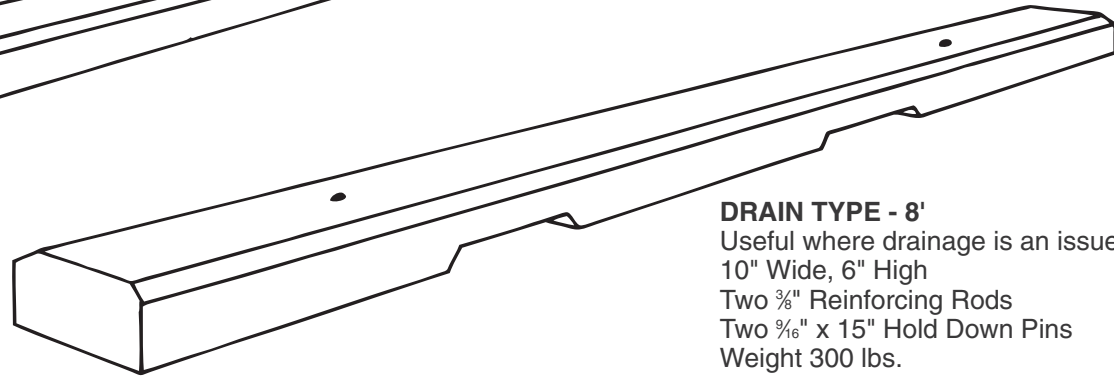

**DRAIN TYPE - 8'**  
Useful where drainage is an issue.  
10" Wide, 6" High  
Two  $\frac{3}{8}$ " Reinforcing Rods  
Two  $\frac{1}{6}$ " x 15" Hold Down Pins  
Weight 300 lbs.

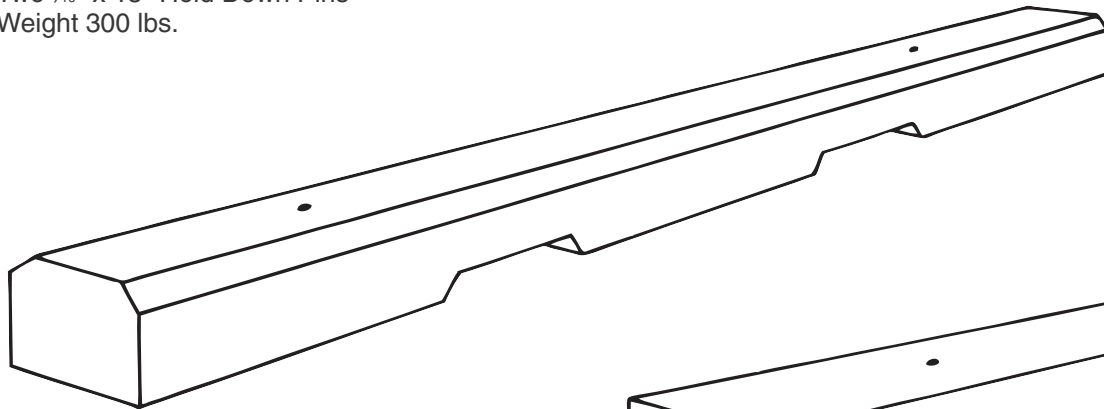

**SUPER TYPE - 8'**  
Popular for added protection with  
taller trucks and SUVs.  
10" Wide, 9" High  
Three  $\frac{3}{8}$ " Reinforcing Rods  
Two  $\frac{1}{6}$ " x 24" Hold Down Pins  
Weight 500 lbs.

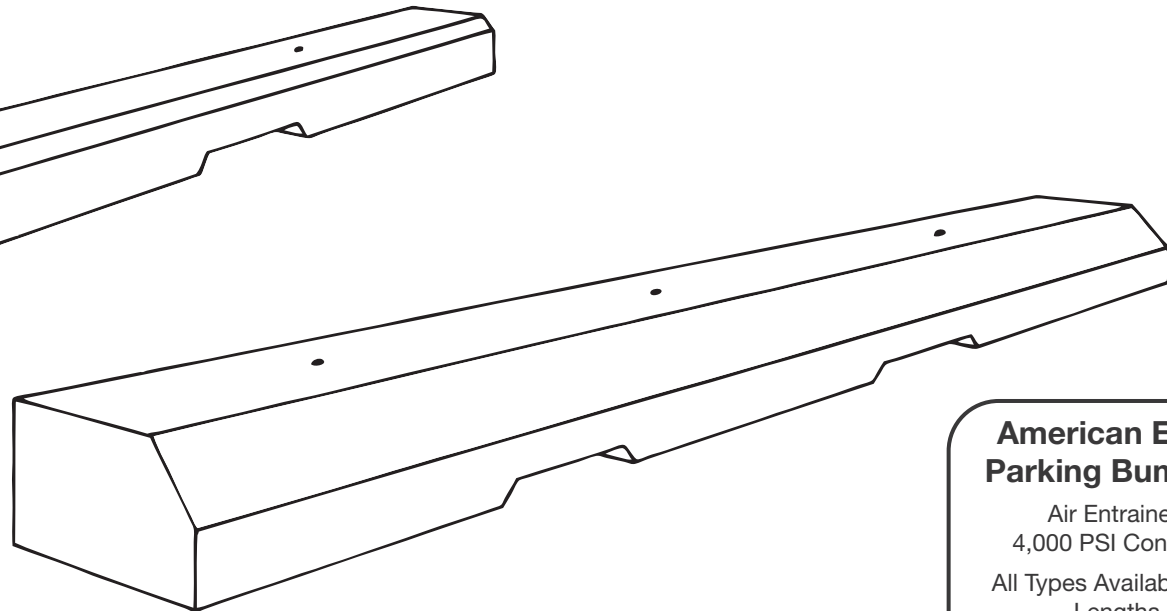

**JUMBO TYPE - 8'**  
A must for truck-trailer parking.  
16" Wide, 12" High  
Five  $\frac{3}{8}$ " Reinforcing Rods  
Two/Three 1" x 36" Hold Down Pins  
Weight 1,350 lbs.

**American Eagle  
Parking Bumpers**

Air Entrained  
4,000 PSI Concrete  
All Types Available in 8'  
Lengths  
Special Sizes Upon Request



**AMERICAN EAGLE PRECAST, LLC**

17301 Conant Avenue Detroit, MI 48212-1198  
Phone: 313-893-6700 Fax: 313-893-5322  
[www.americaneagleprecast.com](http://www.americaneagleprecast.com)